

GENERAL DESCRIPTION

The ADIS1635x/EVAL is a PC-based evaluation system for the Tri-Axis Inertial Sensor (ADIS1635x) family of products. This evaluation system is an extension of the ADISEVAL system, which provides PC Evaluation support for all of the digital ADIS161xx and ADIS162xx products. The ADIS1635x/EVAL includes an ADIS1635xAML sensor, which is already mounted to a board assembly. This assembly provides the SPI-to-Parallel port interface. This kit also includes a parallel cable, and iSensor Documentation CD.

GETTING STARTED

Getting started with this system requires four simple steps.

1. Connect J2 of the Parallel Interface Board (see Figure 14) to the appropriate power supply. For simplicity, Pins 1 and 4 can be tied together and Pins 2 and 3 can be tied together.

Table 1 – Power Supply Hook-up – J2

Pin Number	Function
1	Digital I/O Power Supply
2	Common
3	Common
4	Sensor Power Supply

NOTE: No reverse polarity protection provided.

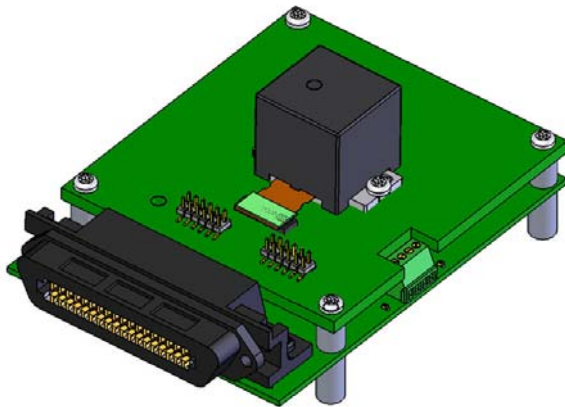

Table 2- Power Supply Voltages

Evaluation Board	Power Supply Voltage
ADIS1635xAMLZ	+4.75 to +5.25V

2. Hook up the system to a PC using the parallel cable provided.
3. Review the ReadMeFirst.pdf file, which is on the iSensor Documentation CD, under, "EVALUATION SOFTWARE DOWNLOADS."
4. Follow the installation steps for the software, located in the ReadMeFirst.pdf file.

SOFTWARE TIPS

The evaluation software is currently designed to work with numerical systems that are compatible with the United States' system. This can create scaling issues in European-based countries, and perhaps others that do not use a "period" to denote the decimal place. A simple way to fix this is to change the regional settings on the test PC, to the US, or comparable North/South American country.

ORDERING GUIDE

Model	Package Description
ADIS16350/EVALZ	ADIS16350 PC Evaluation System
ADIS16354/EVALZ	ADIS16354 PC Evaluation System
ADIS16355/EVALZ	ADIS16355 PC Evaluation System

Rev. PrD

Information furnished by Analog Devices is believed to be accurate and reliable. However, no responsibility is assumed by Analog Devices for its use, nor for any infringements of patents or other rights of third parties that may result from its use. Specifications subject to change without notice. No license is granted by implication or otherwise under any patent or patent rights of Analog Devices. Trademarks and registered trademarks are the property of their respective owners.

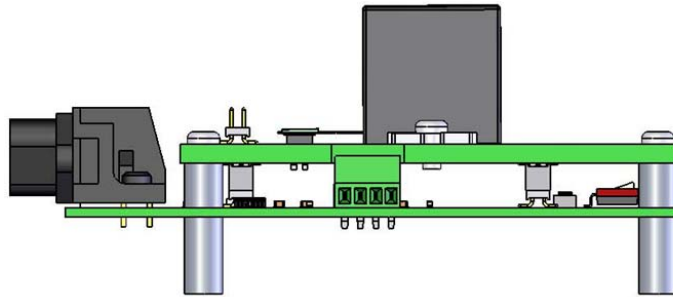

Figure 1. Power Connector Side View

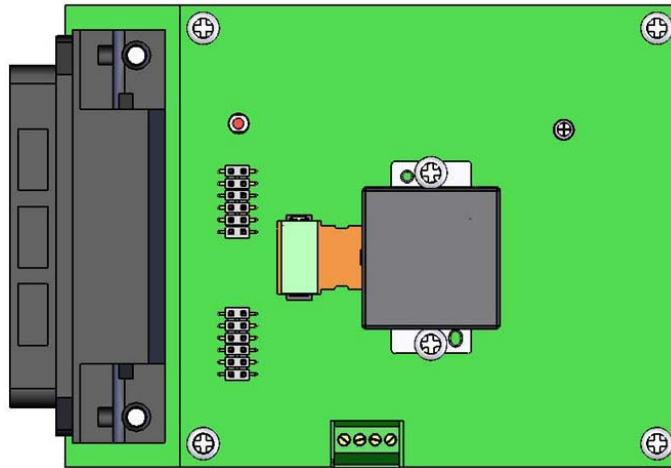

Figure 2. Top View

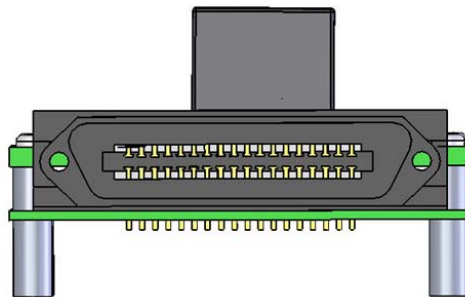

Figure 3. Parallel Port Side View

INITIAL SOFTWARE SETUP

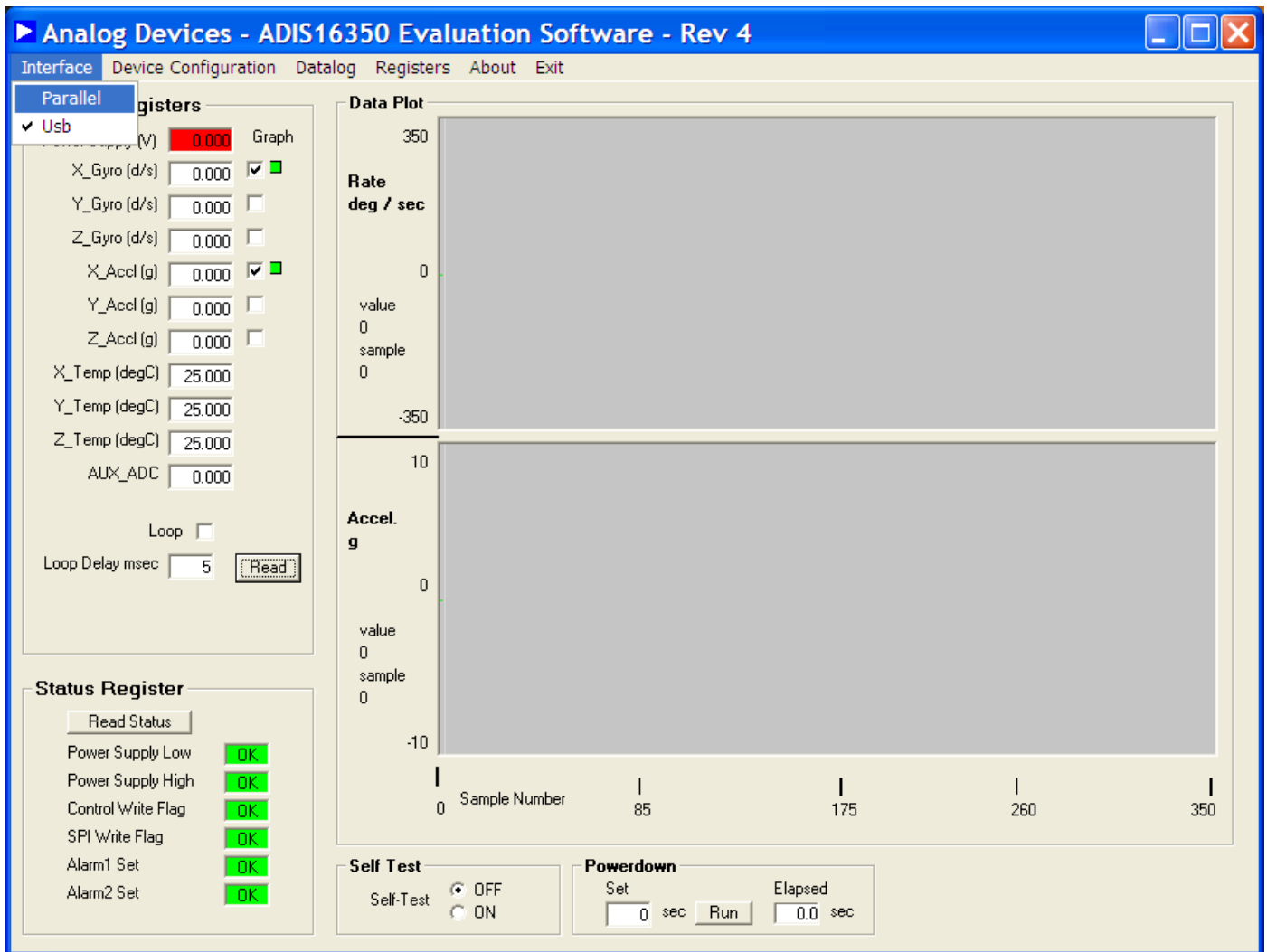

Figure 4. ADIS16350 Evaluation Software, Main Screen

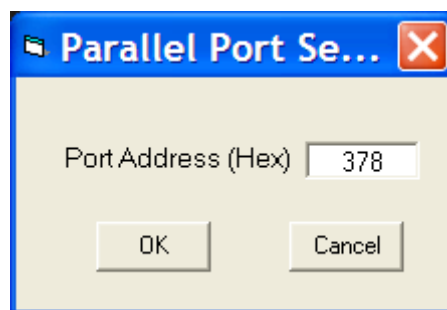
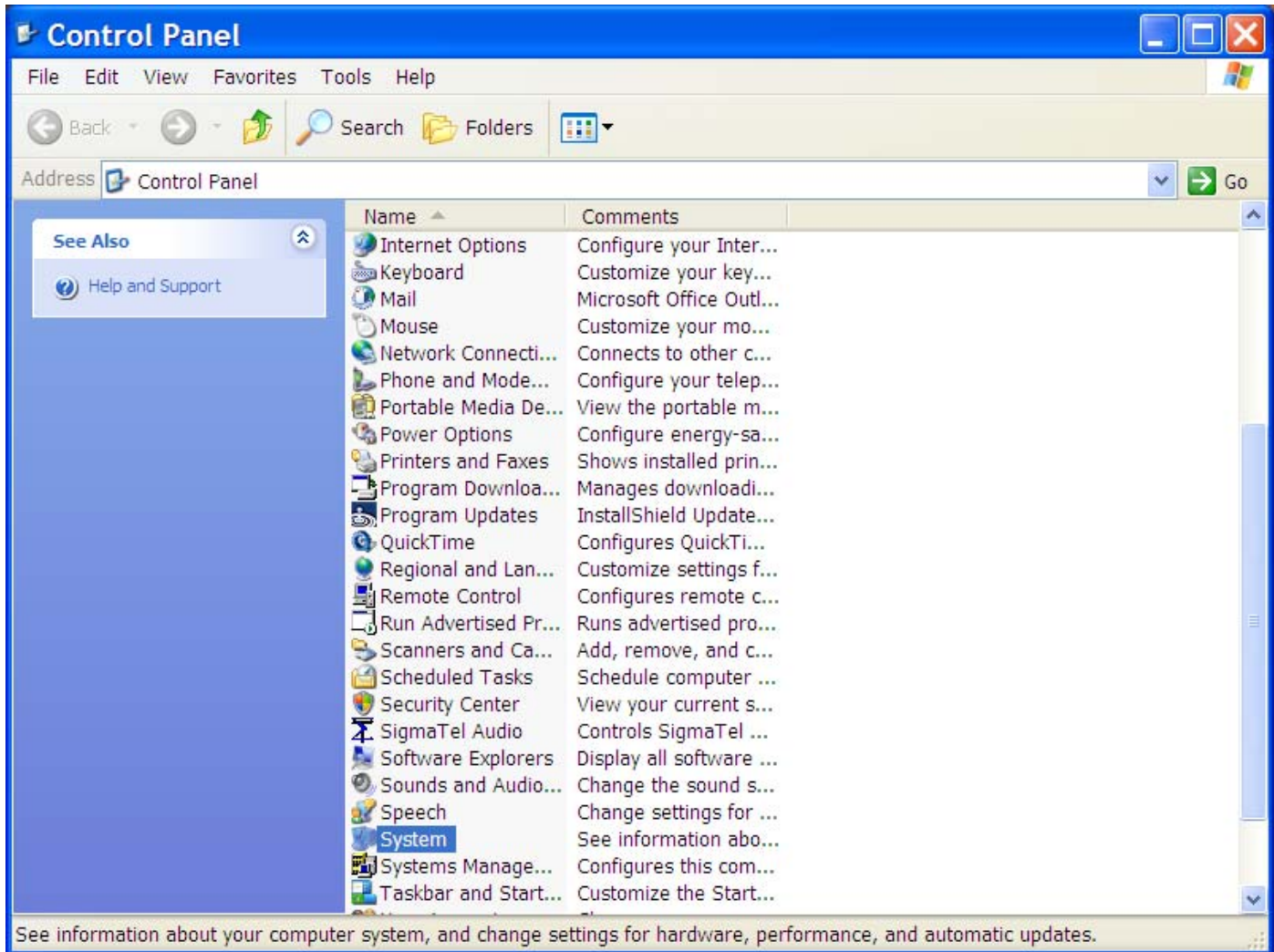

Figure 5. Parallel Port Address Entry

PARALLEL PORT ADDRESS – START IN CONTROL PANEL, THEN CLICK ON “SYSTEM”*Figure 6. Control Panel View*

PARALLEL PORT ADDRESS – FROM SYSTEM, CLICK ON “HARDWARE,” AND THEN THE DEVICE MANAGER.

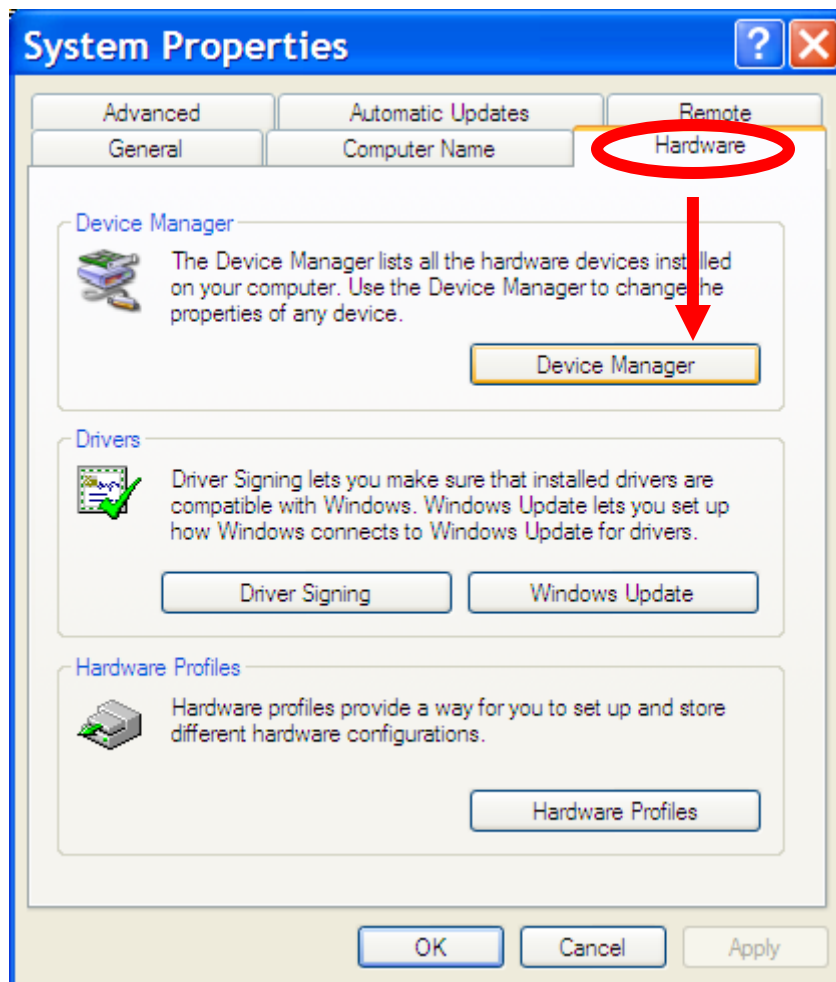

Figure 7. System Properties Window

PARALLEL PORT ADDRESS – IN DEVICE MANAGER, OPEN “PORTS” THEN THE PRINTER PORT

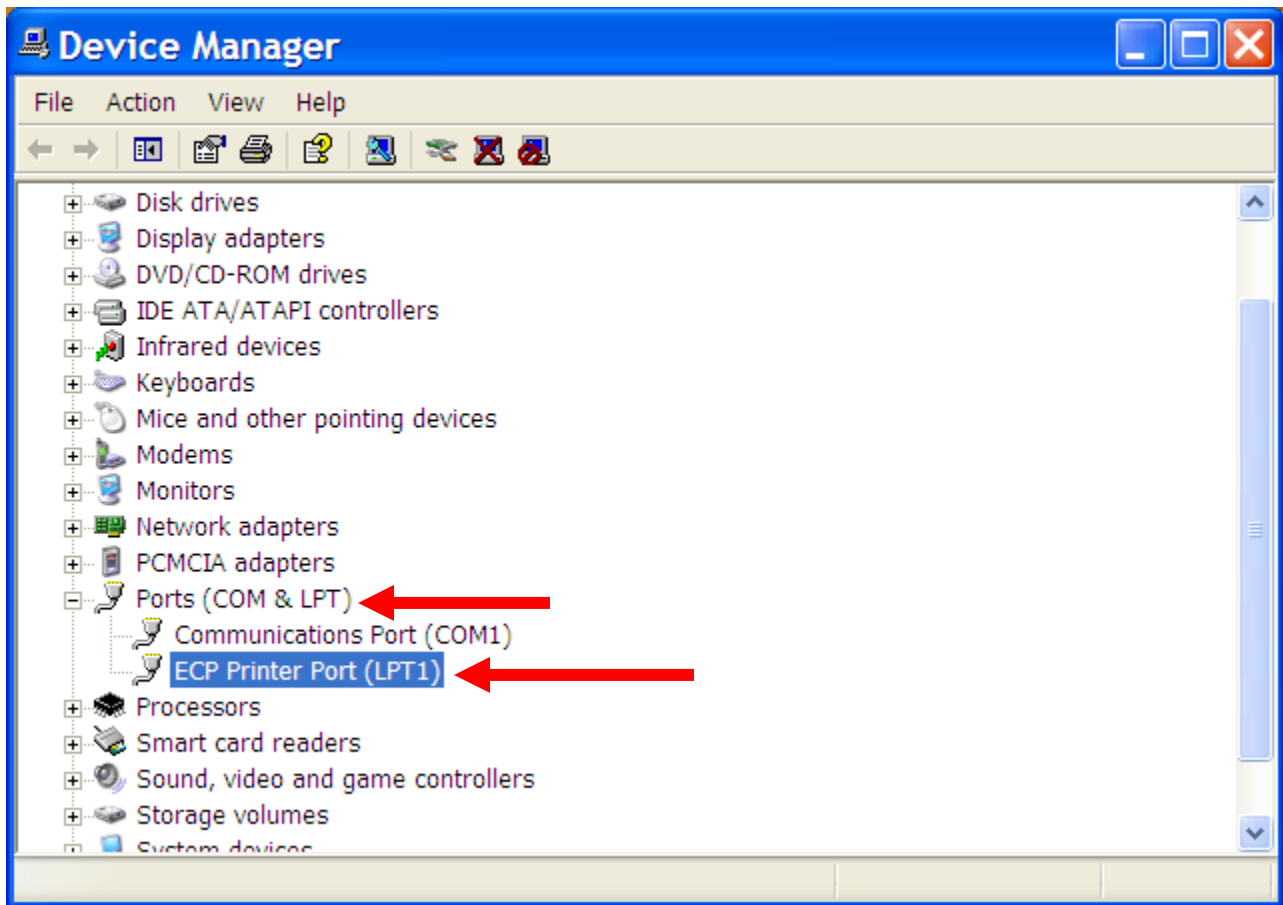

Figure 8. Device Manager Window

SOFTWARE SETUP – CLICK ON RESOURCES, THEN OBSERVE THE ADDRESS

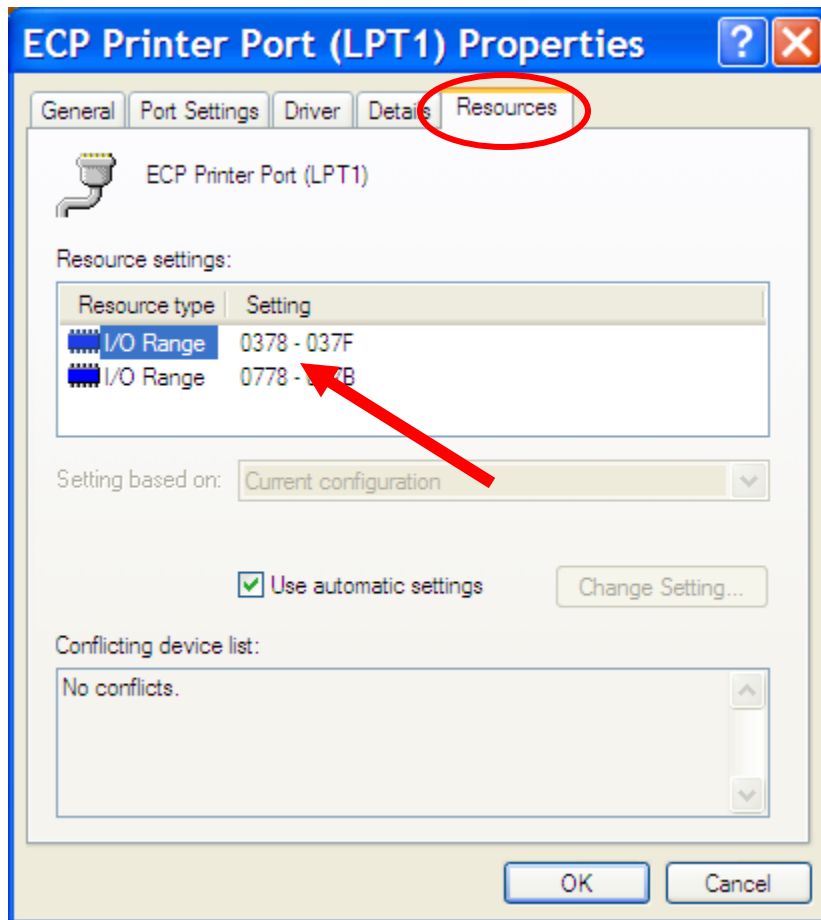

Figure 9. Port Properties

SOFTWARE OPERATION – GETTING STARTED

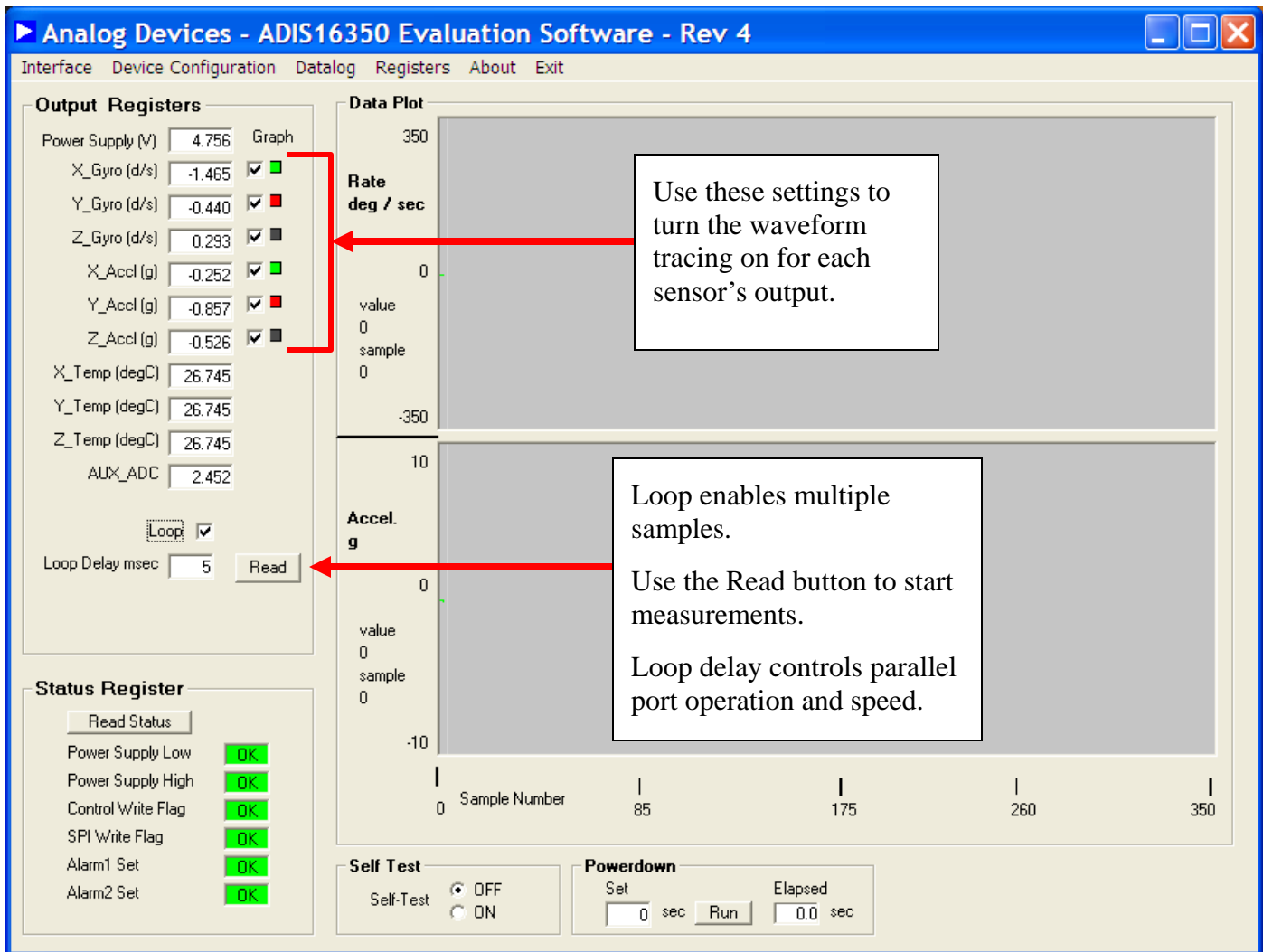

Figure 10. ADIS16350 Main Window, Getting Started

SOFTWARE OPERATION – CALIBRATION

1. TO GET TO THIS WINDOW, CLICK ON “DEVICE CONFIGURATION” DROP-DOWN MENU, AND THEN ON “CALIBRATION”
2. FOR EACH REGISTER BELOW, ENTER THE DECIMAL ADJUSTMENT LEVEL, AND THEN CLICK ON THE UPDATE BUTTON, WHICH WILL LOAD THE REGISTER WITH THE VALUE THAT IS CLOSEST TO WHAT WAS ENTERED. UNTIL UPDATE BUTTON IS CLICKED, THE REGISTER IS NOT CHANGED AND THE PRODUCT CONFIGURATION WILL NOT BE CHANGED.
3. USE FLASH UPDATE TO STORE THE CHANGES IN NON-VOLATILE FLASH.

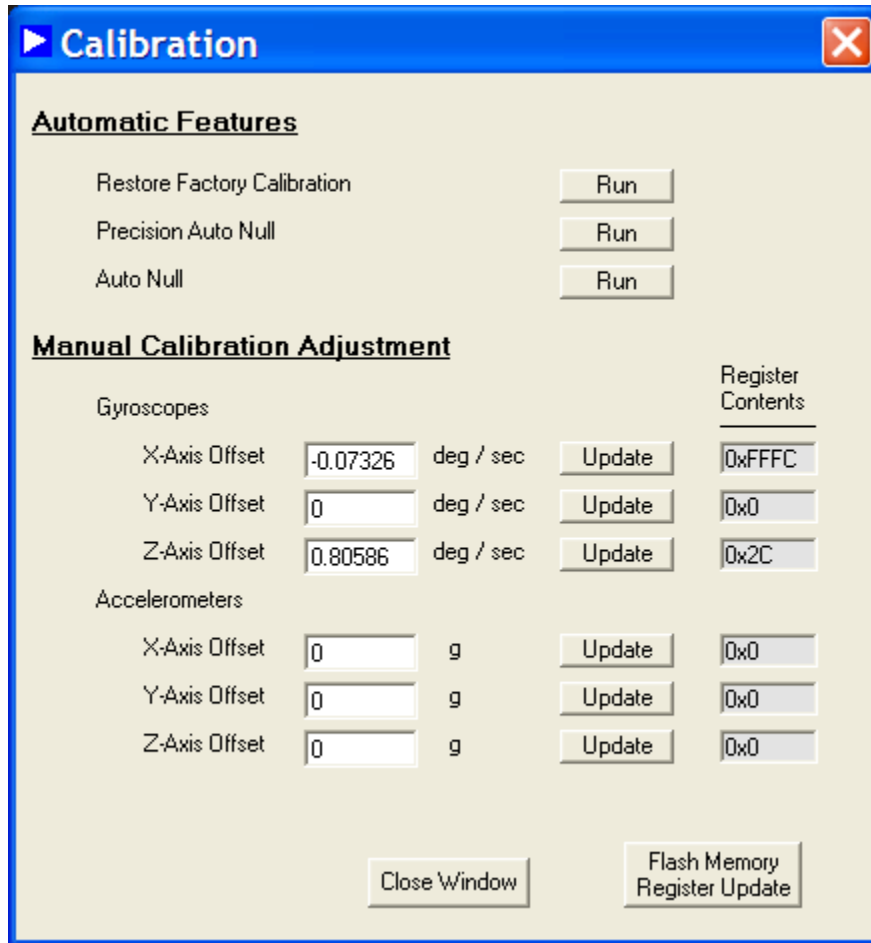

Figure 11. Calibration Control

SOFTWARE OPERATION – CALIBRATION

1. TO GET TO THIS WINDOW, CLICK ON “DEVICE CONFIGURATION” DROP-DOWN MENU, AND THEN ON “OPERATIONAL CONTROL”
2. FOR EACH REGISTER BELOW, ENTER THE DECIMAL ADJUSTMENT LEVEL, AND THEN CLICK ON THE UPDATE BUTTON, WHICH WILL LOAD THE REGISTER WITH THE VALUE THAT IS CLOSEST TO WHAT WAS ENTERED. UNTIL UPDATE BUTTON IS CLICKED, THE REGISTER IS NOT CHANGED AND THE PRODUCT CONFIGURATION WILL NOT BE CHANGED.
3. USE FLASH UPDATE TO STORE THE CHANGES IN NON-VOLATILE FLASH.

Operational Control

Sample Rate

819.202 SPS SMPL_PRD Contents: 0x1 Update

Measurement Range and Digital Filtering

Select Gyro Range: 320 deg/sec 160 deg/sec 80 deg/sec

8 Taps SENS/AVG Contents: 0x403 Update

Auxilliary Digital I/O Configuration

Configure as a general purpose I/O line

Digital I/O Line 0: Input Output Set Line 0 Level: High Low

Digital I/O Line 1: Input Output Read Line 1 Level: High Low

Configure as a data ready line

Select I/O line: DI/00 DI/01 Output Polarity: High Low

Enable: ON OFF

Auxilliary D/A Converter Output

0.0 Volts AUX_DAC Contents: 0x0 Update

Close Window Flash Memory Register Update

Figure 12. Operational Control Window

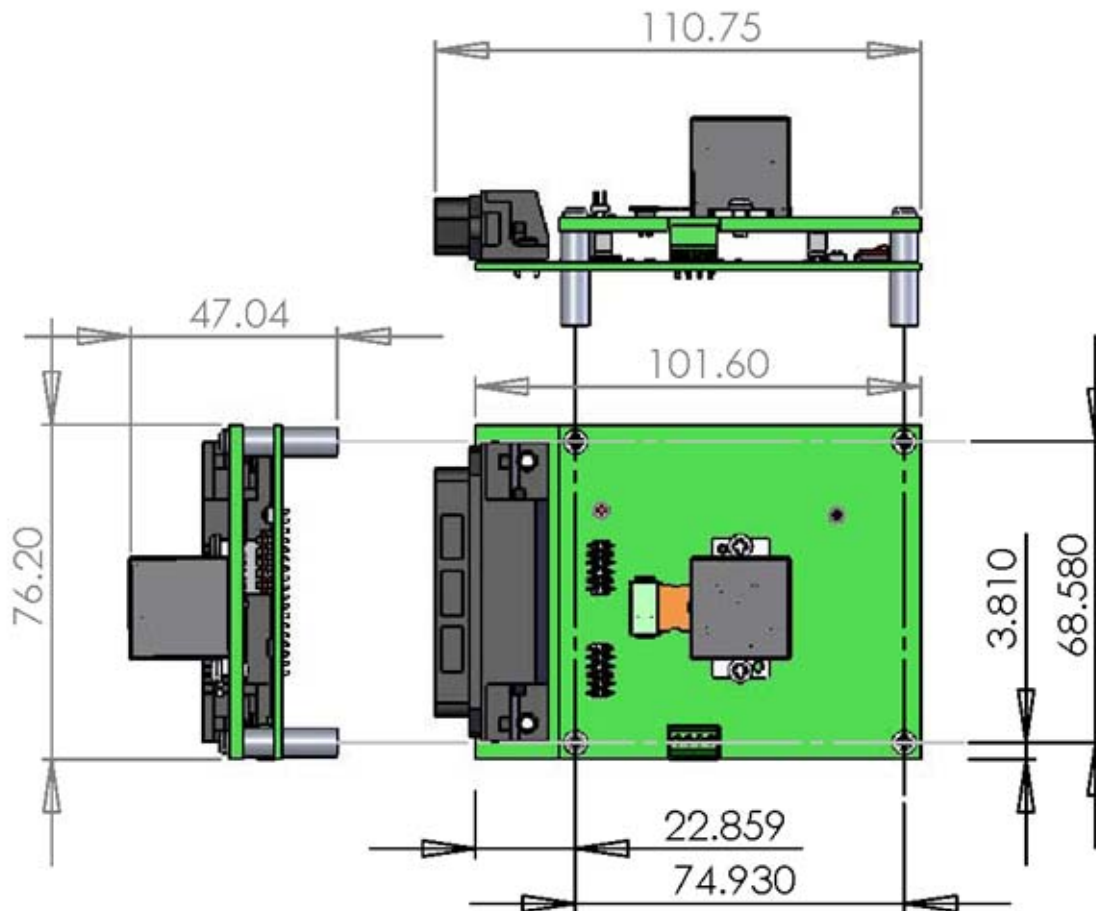
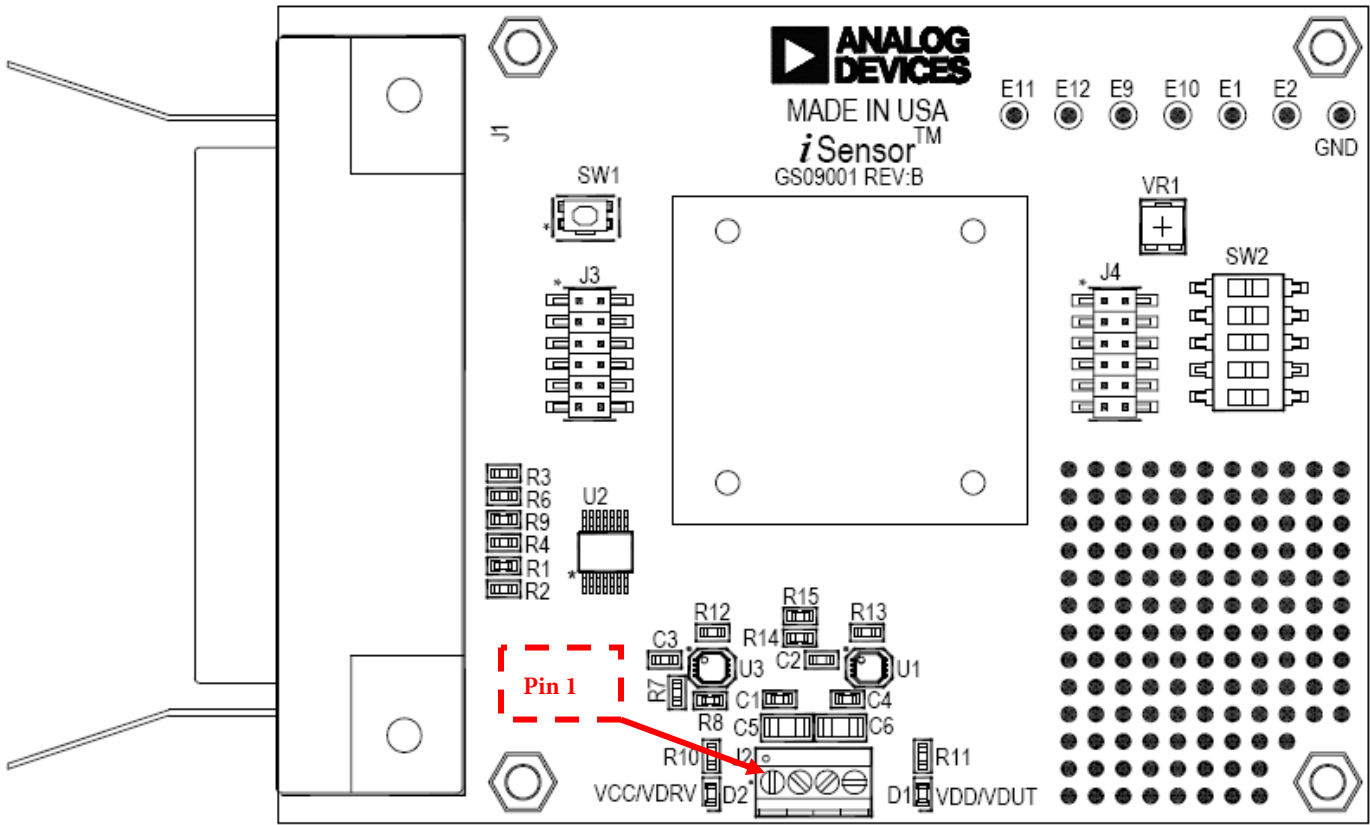

Figure 13. Basic Dimensions



DO NOT INSTALL U1, U3, R7, R8, R14 AND R15.

Figure 14 – iSensor™ PC Interface Board Layout

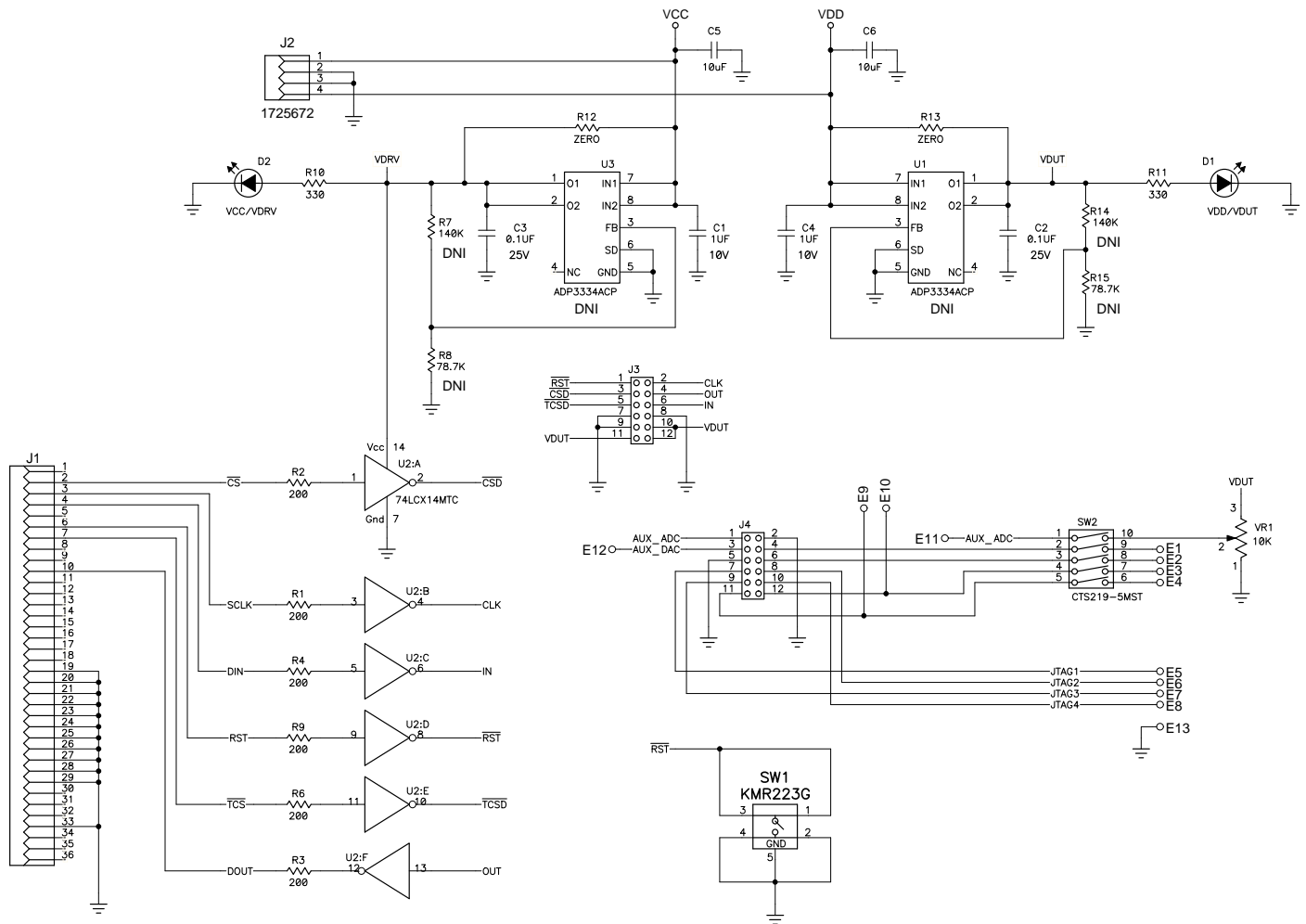

Figure 15 – iSensor™PC Evaluation Board Schematic

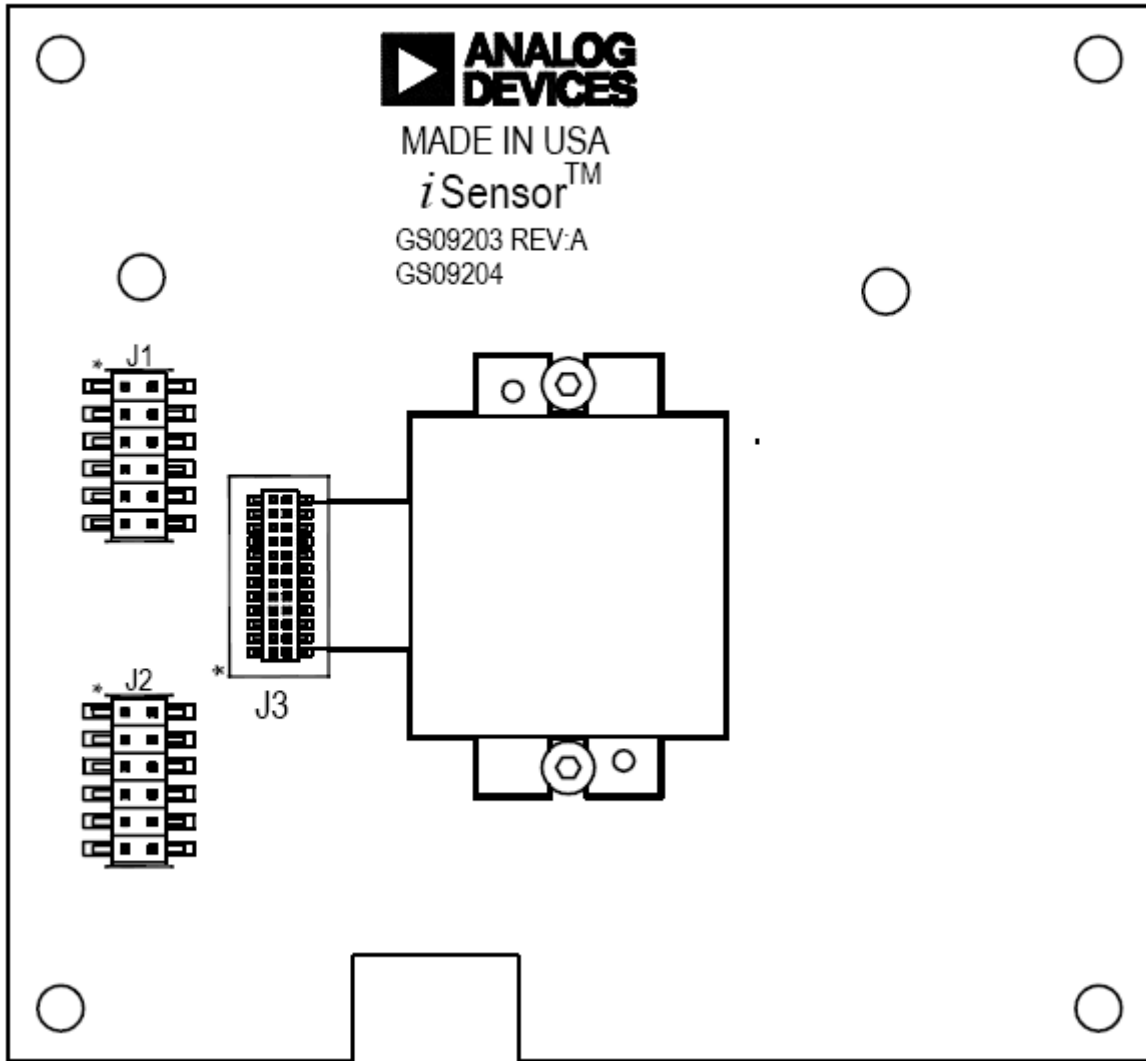

Figure 16 – ADIS16350 Interface Board (Top Side)

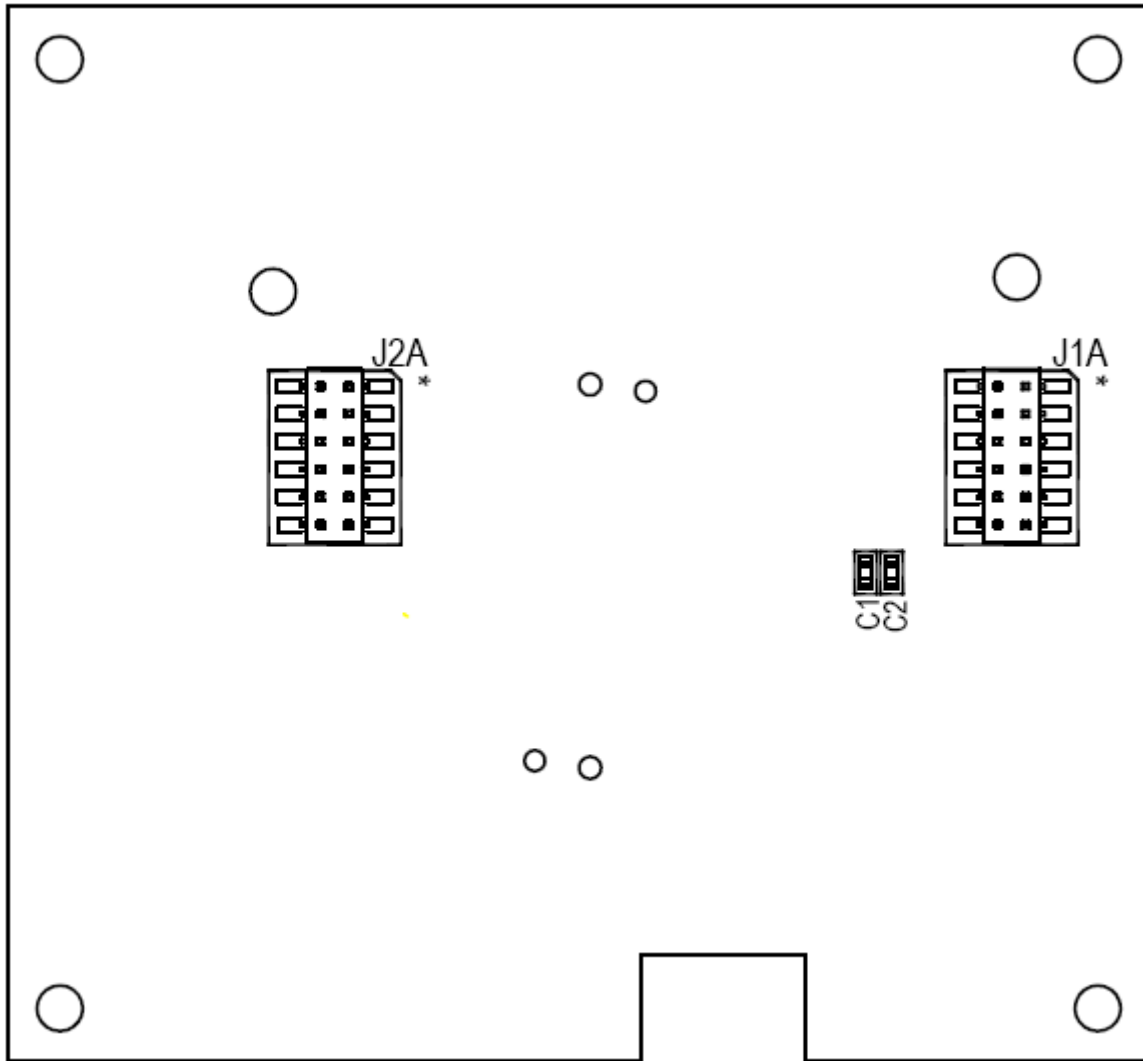

Figure 17 – ADIS16350 Interface Board (Bottom Side)

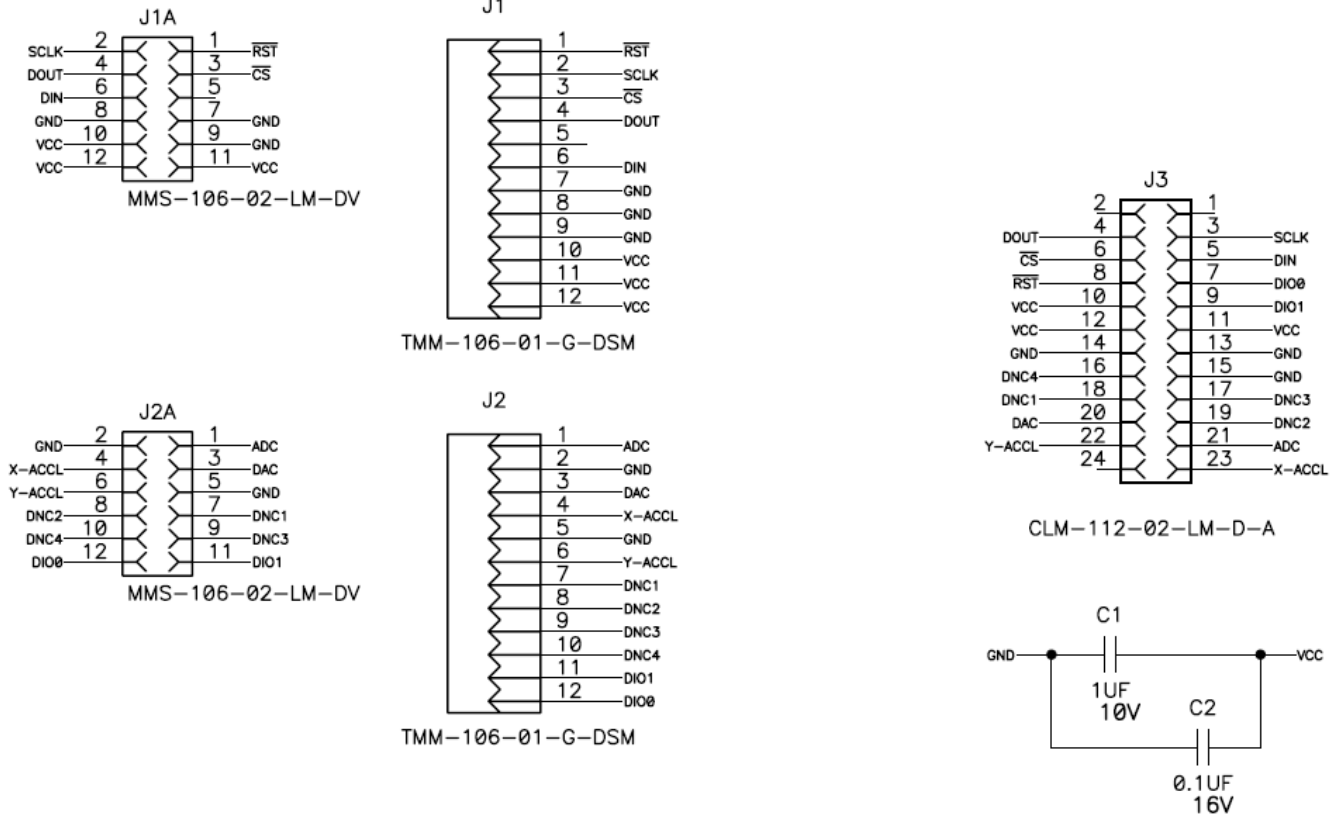

Figure 18 – ADIS16350 Interface Board Schematic, Pin Assignments